

# Roads and Wildlife



Jens Hilke, Conservation Planner



Andrea Wright, Environmental Policy Manager



# WHY SHOULD WE CARE?

Safety!

Economic

- \$8 Billion/Year in Property Damages nationally
- Cost to society per collision
  - Deer \$7,000
  - Moose \$30,000

Stewardship – keeping common species common



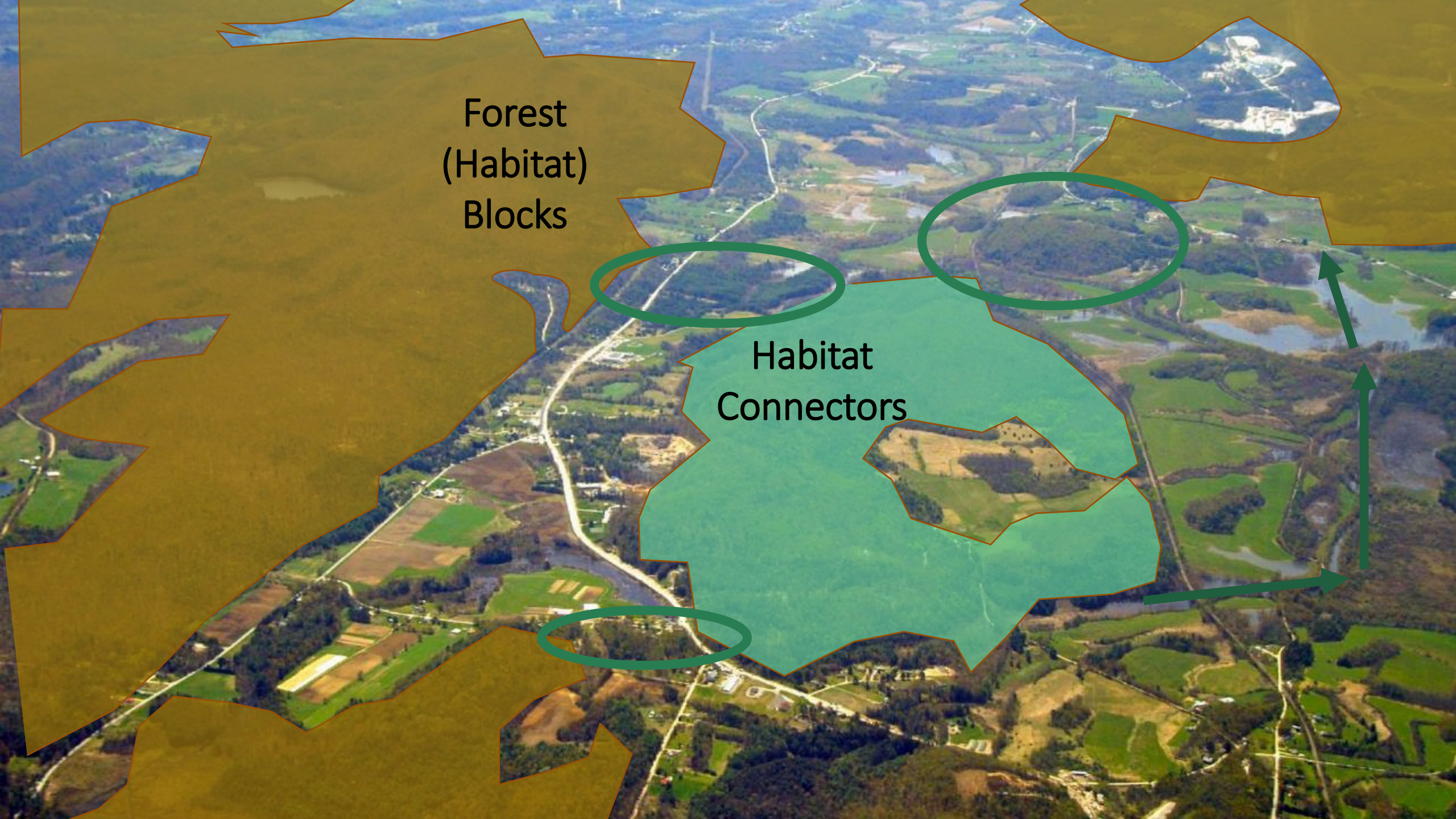

Forest  
(Habitat)  
Blocks

Habitat  
Connectors

**VERMONT CONSERVATION DESIGN IS A SCIENCE-BASED  
VISION TO SUSTAIN THE STATE'S VALUED NATURAL AREAS,  
FORESTS, WATERS, WILDLIFE, AND PLANTS FOR FUTURE  
GENERATIONS**

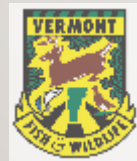

See VCD on



<https://anrmaps.vermont.gov/websites/BioFinder4/>

# LANDSCAPE SCALE

# COMPONENTS

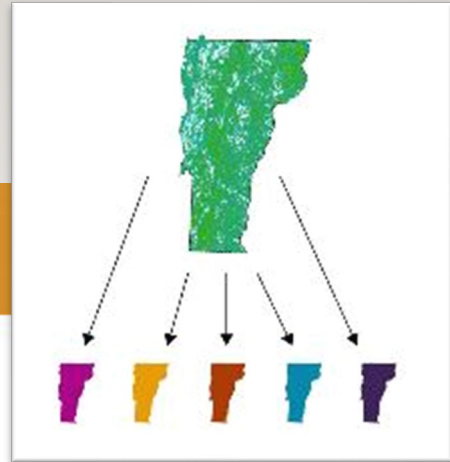

## INTERIOR FOREST

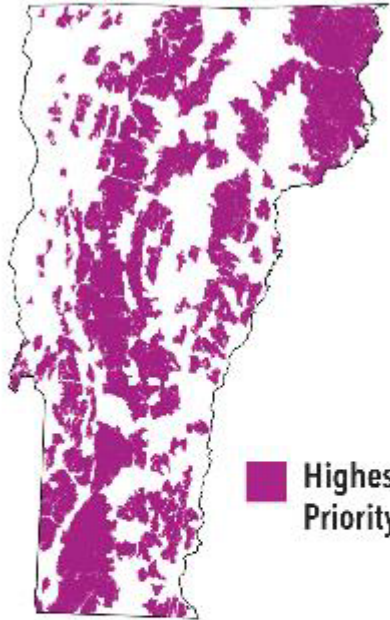

The largest forest blocks in each biophysical region. These are areas of contiguous forest and other natural communities and habitats (such as wetlands, ponds, and cliffs) that are unfragmented by roads, development, or agriculture.



## CONNECTING FOREST

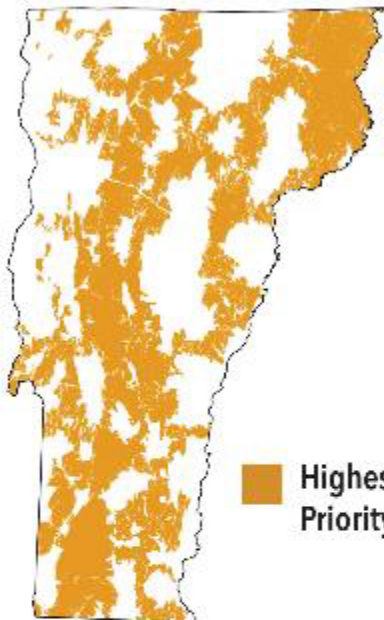

The network of forest blocks that together provide terrestrial connectivity at the regional scale (across Vermont and to adjacent states and Québec) and connectivity with surface waters and areas of geological diversity.



## GEOLOGICAL DIVERSITY

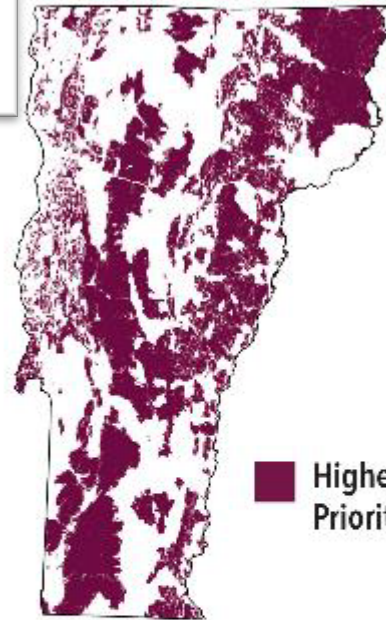

A set of forest blocks that reflect the full diversity of Vermont's bedrock, soils, elevations, and landforms (features such as slopes, ridges, flats, and coves). Diversity in the physical landscape is linked to biological diversity, and places that contribute to physical diversity will be important for biological diversity even as the climate changes.



## SURFACE WATERS & RIPARIAN AREAS

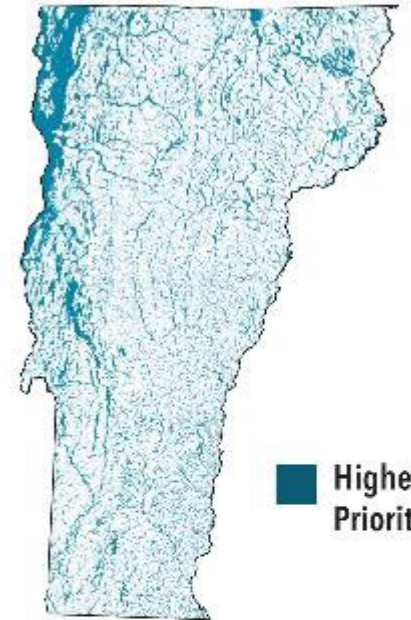

The network of all lakes, ponds, rivers, and streams, their associated riparian zones, valley bottoms, and river corridors in which geophysical processes occur.



# WILDLIFE ROAD CROSSINGS

- >75% = Highest Priority
- >50% = Priority
- >5% = Potential Wildlife Road Crossing

percent habitat block of each plot

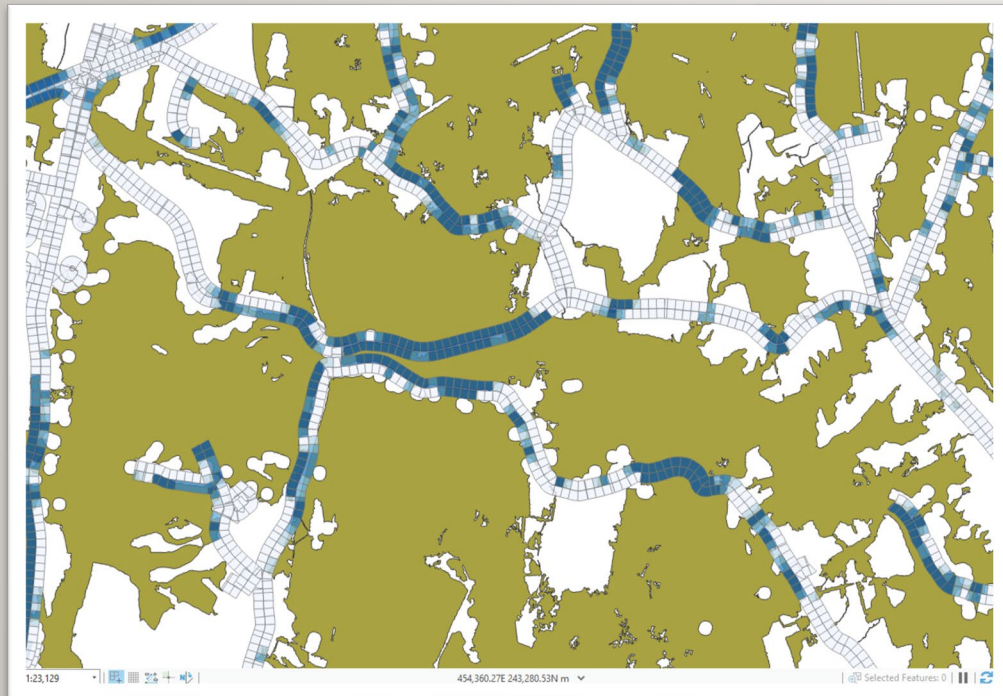

Georgia



Georgia



- **Male Bobcats moved 19 miles / day**
- Home Range:**
  - **27 square miles (Male)**
  - **8.8 square miles (Female)**

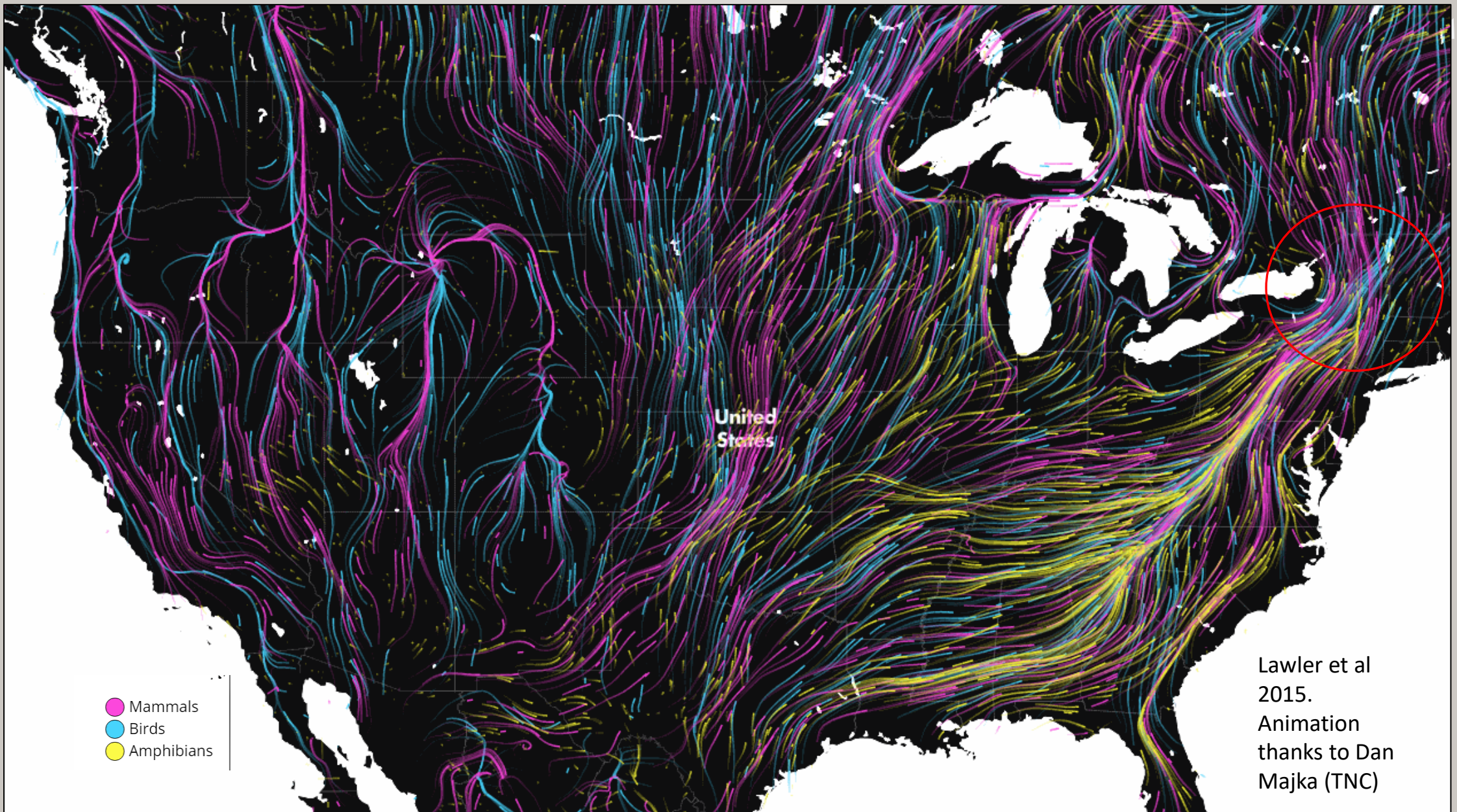

The gradual movement of populations across the landscape in response to climate change  
**Current Rates: 11 mile per decade North 36 feet per decade Upslope**

# Culvert Replacement Rt 15 Hyde Park Bridge 42

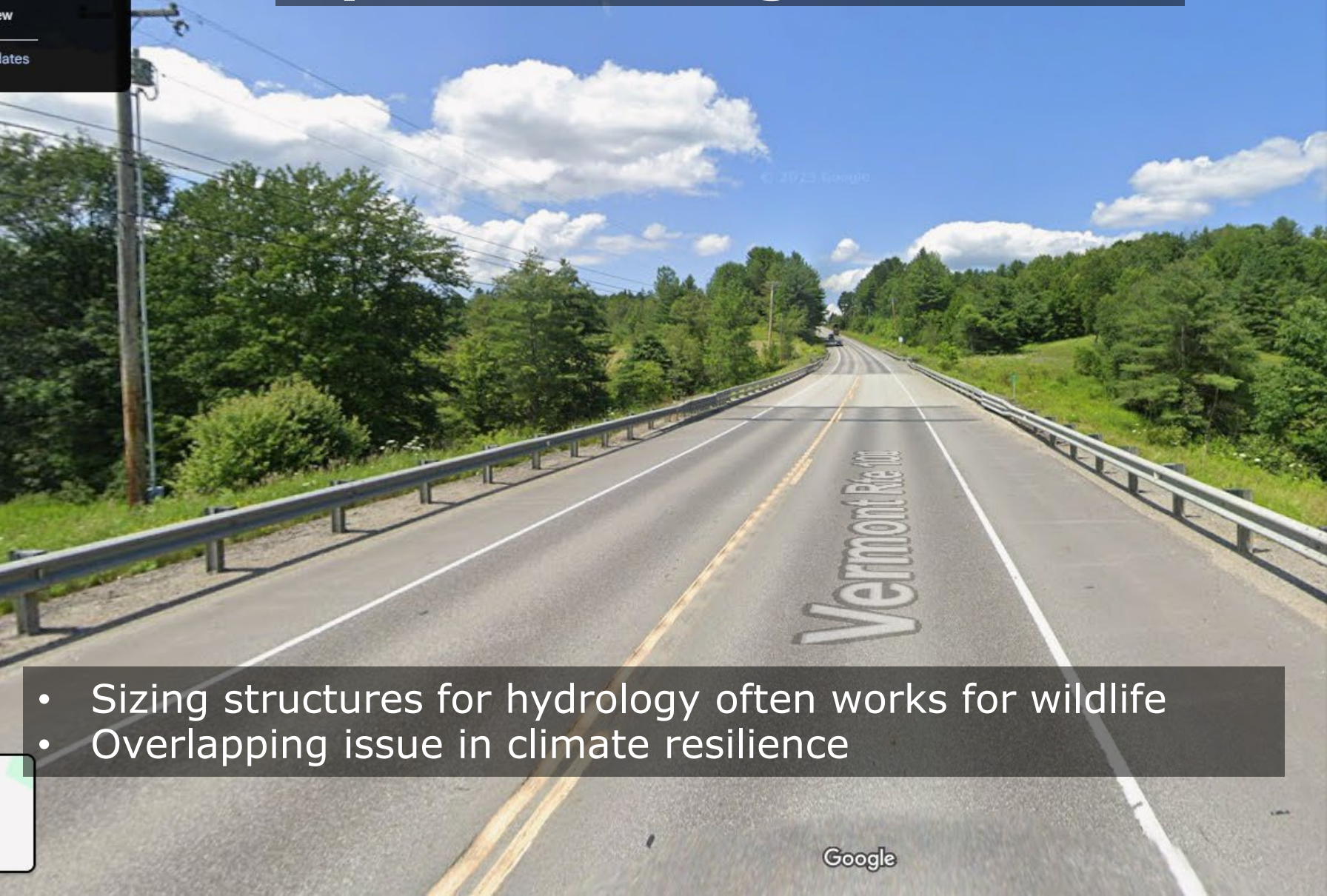

- Sizing structures for hydrology often works for wildlife
- Overlapping issue in climate resilience



Old Culvert in 20



Replaced in 20

# 5 Replacements along Rt 12 (“Moose Alley”)

- Construction 2024 - 2025
- VT’s Hydrologic standards for sizing yield great results for wildlife
- Huge investments in adjacent land protection and land use planning

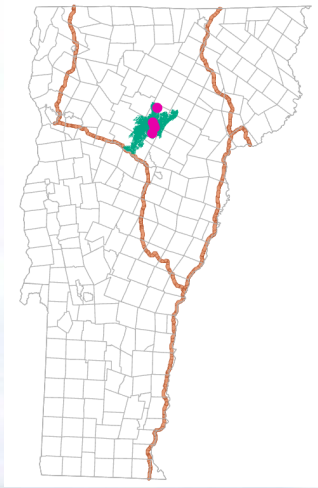

Bridge 89  
Existing is 15' wide  
Replacement: 77' span  
bridge



# WILDLIFE SHELF – RT 12 IN WORCESTER



# VT 9 IN SEARSBURG



Constructed in 2004  
Extended span  
Allows for floodwaters, Aquatic & terrestrial wildlife movement



Canada Lynx

2018-06-12 1:07:55 PM M 3/3 76°F



Black Bear & Cubs

# Little River Wildlife Shelf under I 89 (2014)

- ~ \$20,000 retrofit on a \$8mill project
- Now a standard specification on all bridges with sufficient space
- Has allowed for movement of almost every VT mammal species

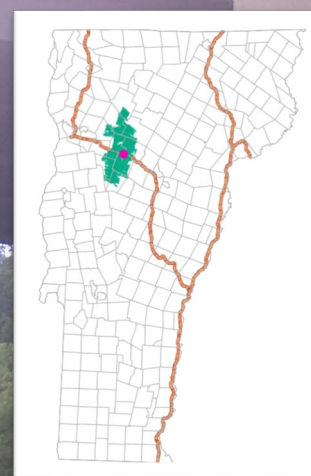

2014-05-31 4:09:58 AM M 1/3 0 50°F



# WILDLIFE SHELF STANDARD

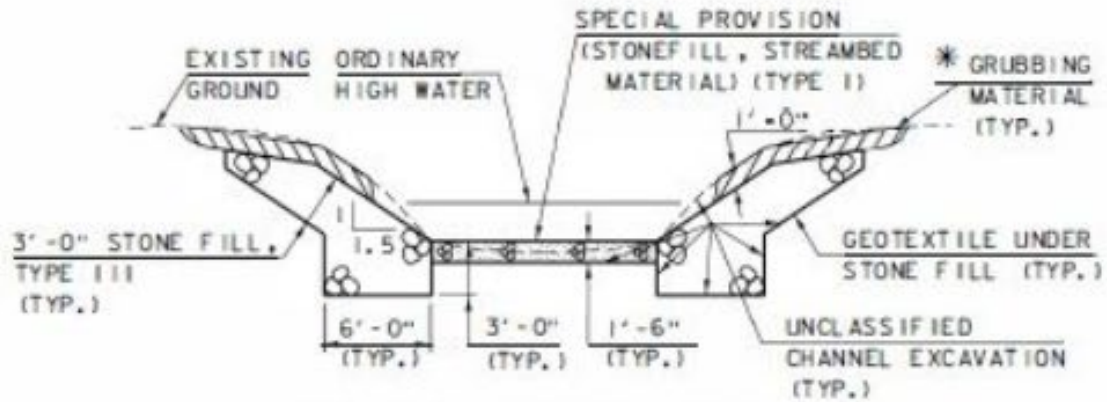

**TYPICAL CHANNEL SECTION**  
(NOT TO SCALE)

\*GRUBBING MATERIAL SHALL BE PLACED ON THE STONE FILL IN THE AREA UNDER THE BRIDGE. WHENEVER CHANNEL SLOPE INTERSECTS ROADWAY SUBBASE, GRUBBING MATERIAL SHALL BEGIN AT THE BOTTOM OF SUBBASE.



**Rt 15 in Wolcott, wildlife shelf constructed in 2022**

# Reconnecting The Green Mountains

## Mansfield to Camel's Hump Wildlife Corridor

- Current investments in adjacent land protection and land use planning

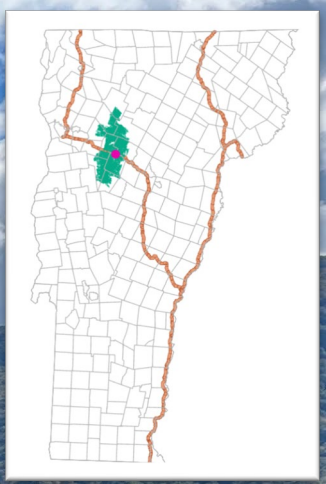

# Reconnecting The Green Mountains

## Mansfield to Camel's Hump Wildlife Corridor

- Current investments in adjacent land protection and land use planning

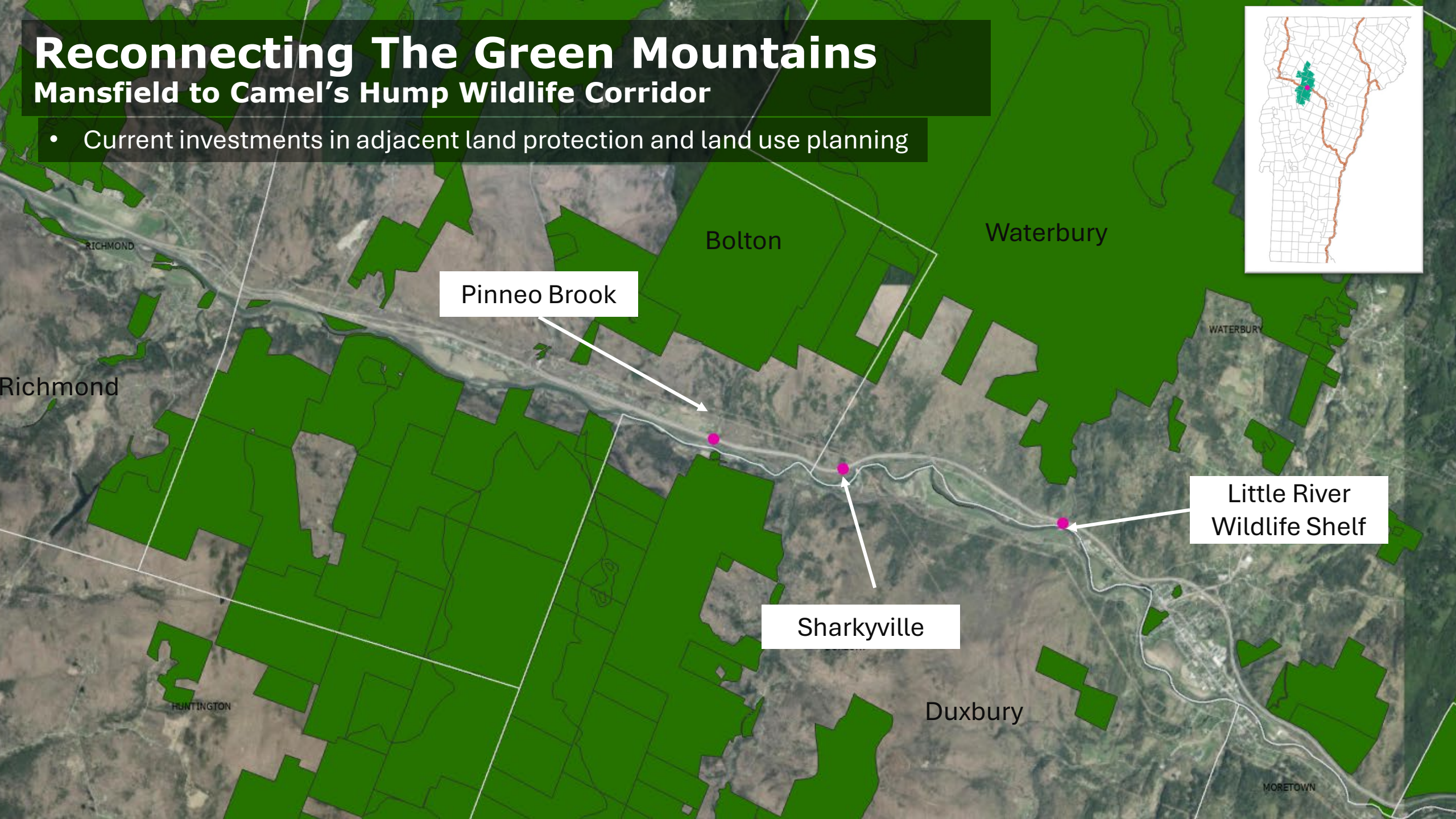

RICHMOND

Bolton

Waterbury

WATERBURY

Richmond

Pinneo Brook

Little River  
Wildlife Shelf

Sharkyville

Duxbury

HUNTINGTON

MORETOWN

# BOLTON ZONING SUCCESS

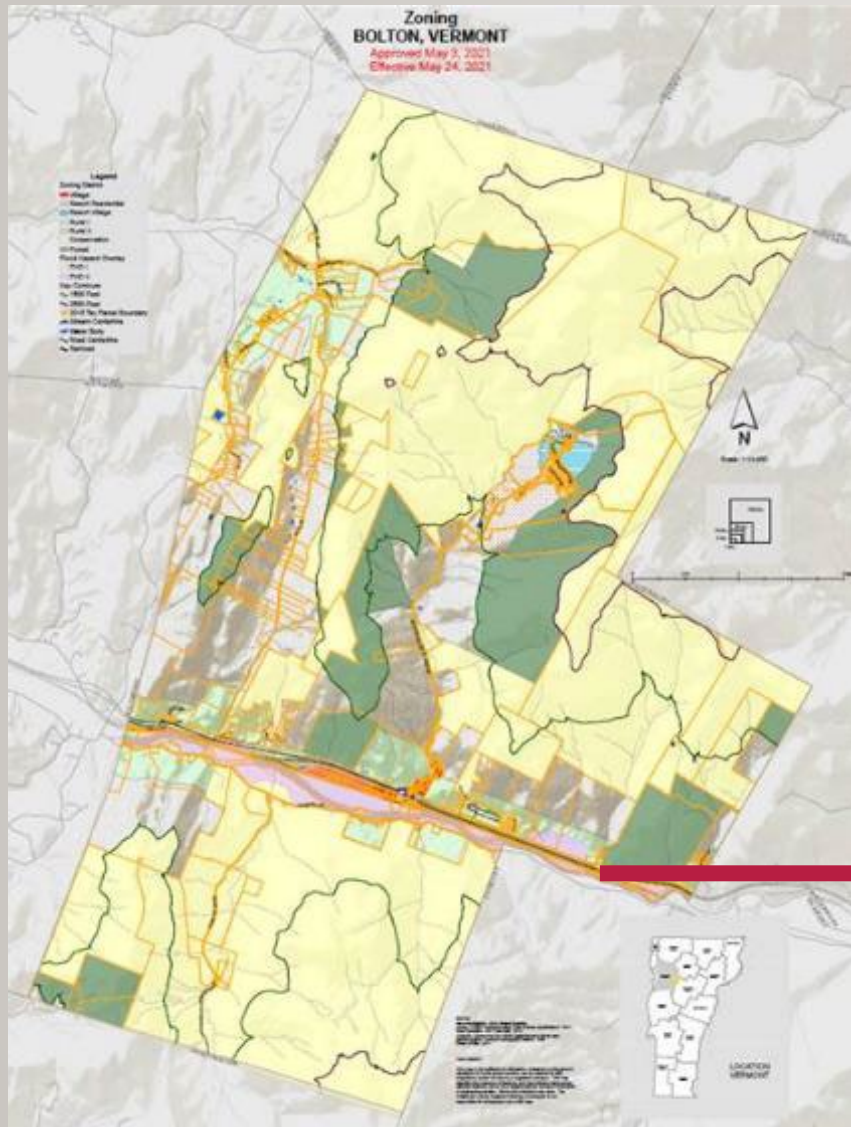

Pinneo Brook Culvert

# Monkton Amphibian Crossing



Exclusionary Fencing  
Funnel Wildlife to the  
crossing

Culvert / Wildlife  
Passage



# MONKTON AMPHIBIAN CROSSING

2016-08-19 4:30:42 AM M 1/3

67°F

2021-08-23 10:20:04 PM M 3/3

74°F



PC900 PROFESSIONAL

RECONYX



C922

RECONYX

# HIGHWAYS & HABITATS TRAININGS

- Three-tiered training for VTrans staff
- Offered since 2004



# ROAD CROSSING DATA COLLECTION



[Intro](#) | [Map](#) | [Downloading the app](#) | [Instructions](#) | [Downloading the data](#) | [Credits & Contact](#)

## Why care about roadkill data?

Why did the bear cross the road? To get to the other side is the common answer. But as we dig into that, we realize there is more to it than that. All animals need food, water, shelter and access to mates. Some movement across the road, particularly among species with big home ranges, is to meet these basic needs. Different food sources are available in different spots at different times of year. So, some species move around a lot to get what they need. A black bear might utilize lower elevation wetlands in the spring, as they are home to some of the first plants to green up. In the summer they might eat berries in open meadows and in the fall gorge on beech nuts and acorns up on the ridges. That might take them across many roads over the course of a year and they'll use several forest blocks. A single black bear can have a home range of 10,000 to 20,000 ac. Similarly, radio tracking data from the Champlain Valley shows male bobcats have a 27mi home range, moving approximately 19 miles each day.



Some movement is annual migration. Each spring salamanders emerge from underground in forested uplands and move downslope (often across a road) to wetlands where they breed and then head back up the hill. This is a movement of perhaps only 600', but in places where this happens, thousands of animals might cross a road in a single night in the spring.

Lastly, many species are adjusting their home ranges in response to a warming climate. The Nature Conservancy estimates entire populations are moving north and south away from the equator at about 1 mile per year. That's entire populations adjusting their ranges! In Vermont, that movement is not just south to north. Wildlife crossing usually happens where wetlands and forests are close to both sides of the road. Where streams and rivers go under the road can be an excellent spot for wildlife crossing and many of our bridges and culverts do facilitate that kind of movement. Some structures, particularly older ones often do not.



# Wildlife Transportation Action Plan

## Structure Prioritization

- 1,285 Structures
- Statewide distribution
- Prioritized to facilitate statewide connectivity
  - Highest Priority Connectivity Blocks
  - Highest Priority Wildlife Road Crossings
  - Staying Connected Initiative Linkage Areas
  - Connectivity Focus Areas

☑ Wildlife Transportation Action Plan Structures

Condition rating

● 1 - Good

● 2 - Fair

● 3 - Poor

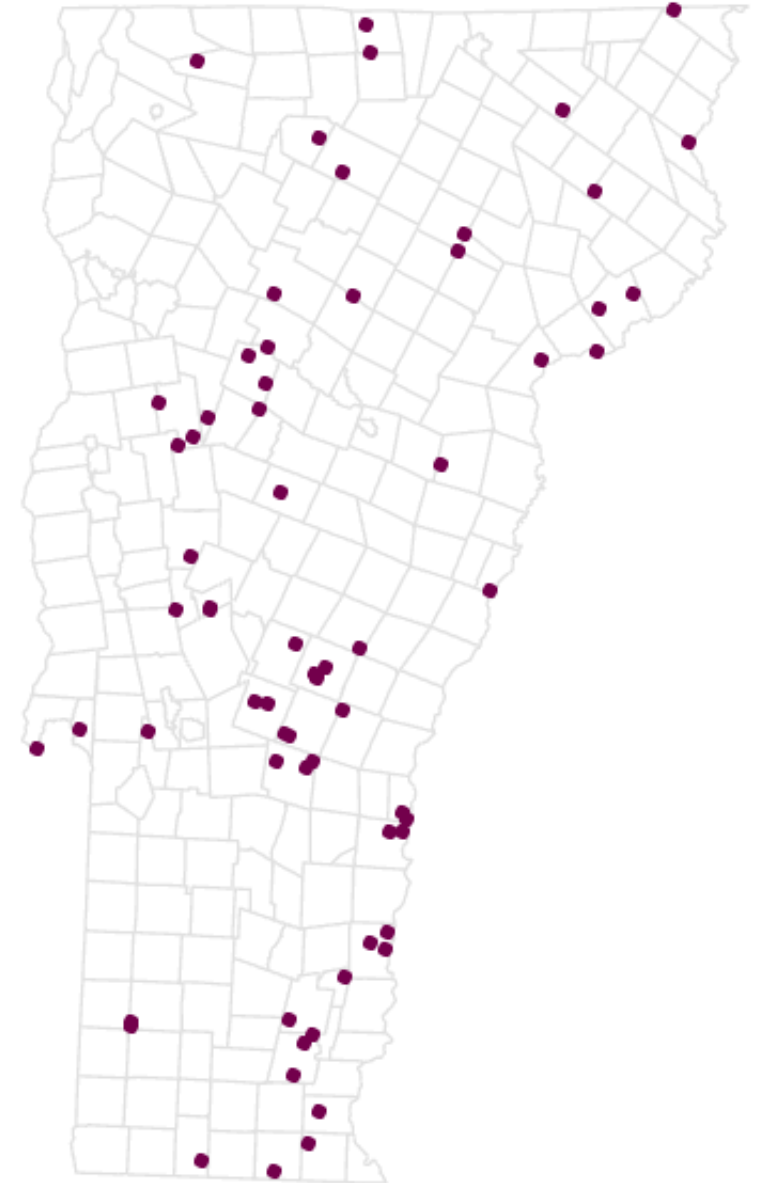

# Help Prevent Roadkill

Do you notice, the Roadkill!!

Well scan this QR code, it will take you to the Fish and Wildlife web site, the app will help you, if you hit an animal or see an animal on the side of the road, so please scan the QR code for the animals in Vermont.

THANK YOU FOR YOUR HELP!

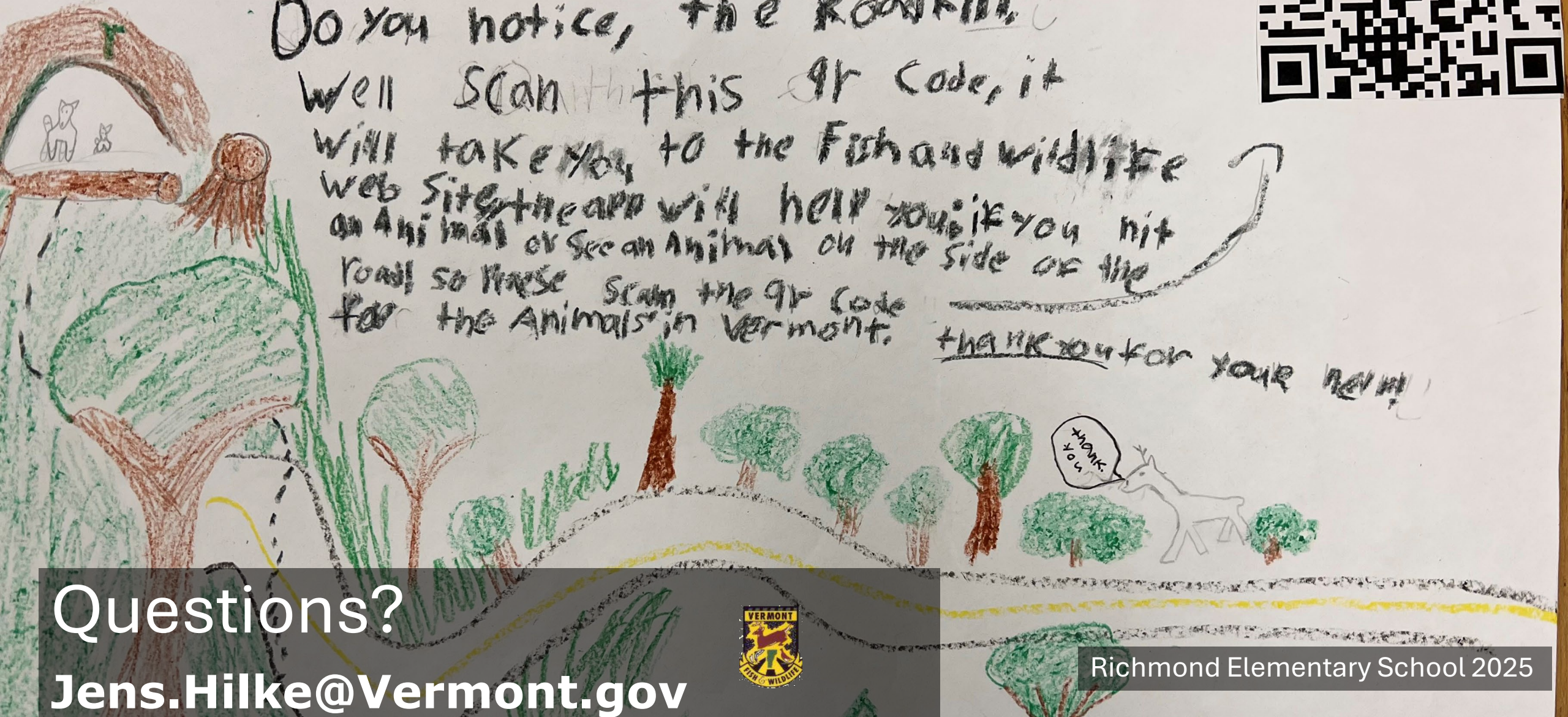

Questions?

Jens.Hilke@Vermont.gov



Richmond Elementary School 2025