

Asset Management Bureau



*"Who are we
and what do
we do?"*

Chad A. Allen, P.E., Director
Asset Management Bureau

January 17, 2019

Planning & Programming

Design

Data Inventory

Data Quality

Data Reporting

AM Lifecycle

Data Efficiency

Data Systems

Maintenance

Construction

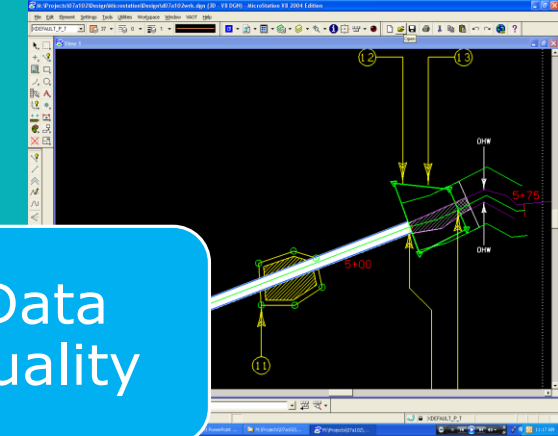
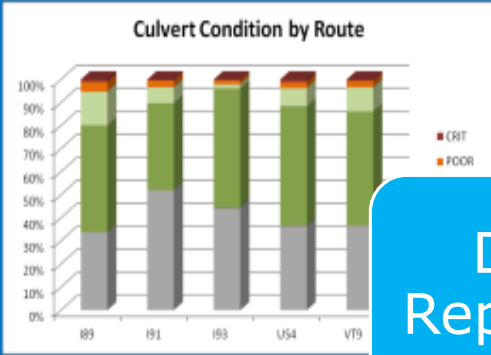

○ What & Why?

The AMP's overall mission is to coordinate the **programming** of capital improvement projects and maintenance activities at strategic points in an asset's life cycle to extend its useful life. To **increase network level asset condition and performance, enhance customer service, and minimize lifecycle costs to maximize stakeholder benefit.**

○ How?

By meeting the required customer service levels, in the most cost effective manner through the management of assets for both present and future customers.

Who we are...

How we became who we are...

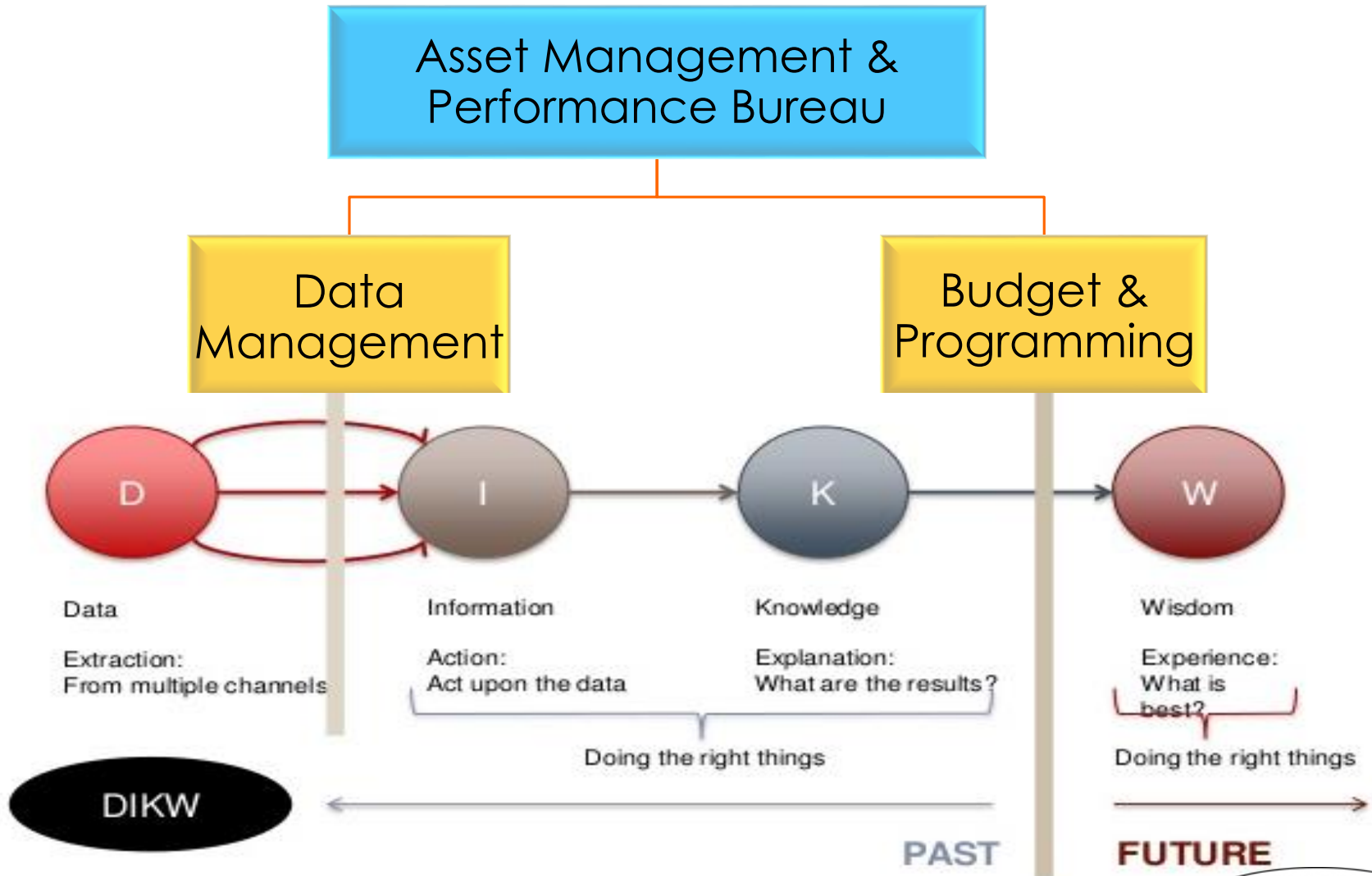

Who we are...



Agency of Transportation

Highway Division

Asset Management and
Performance Bureau

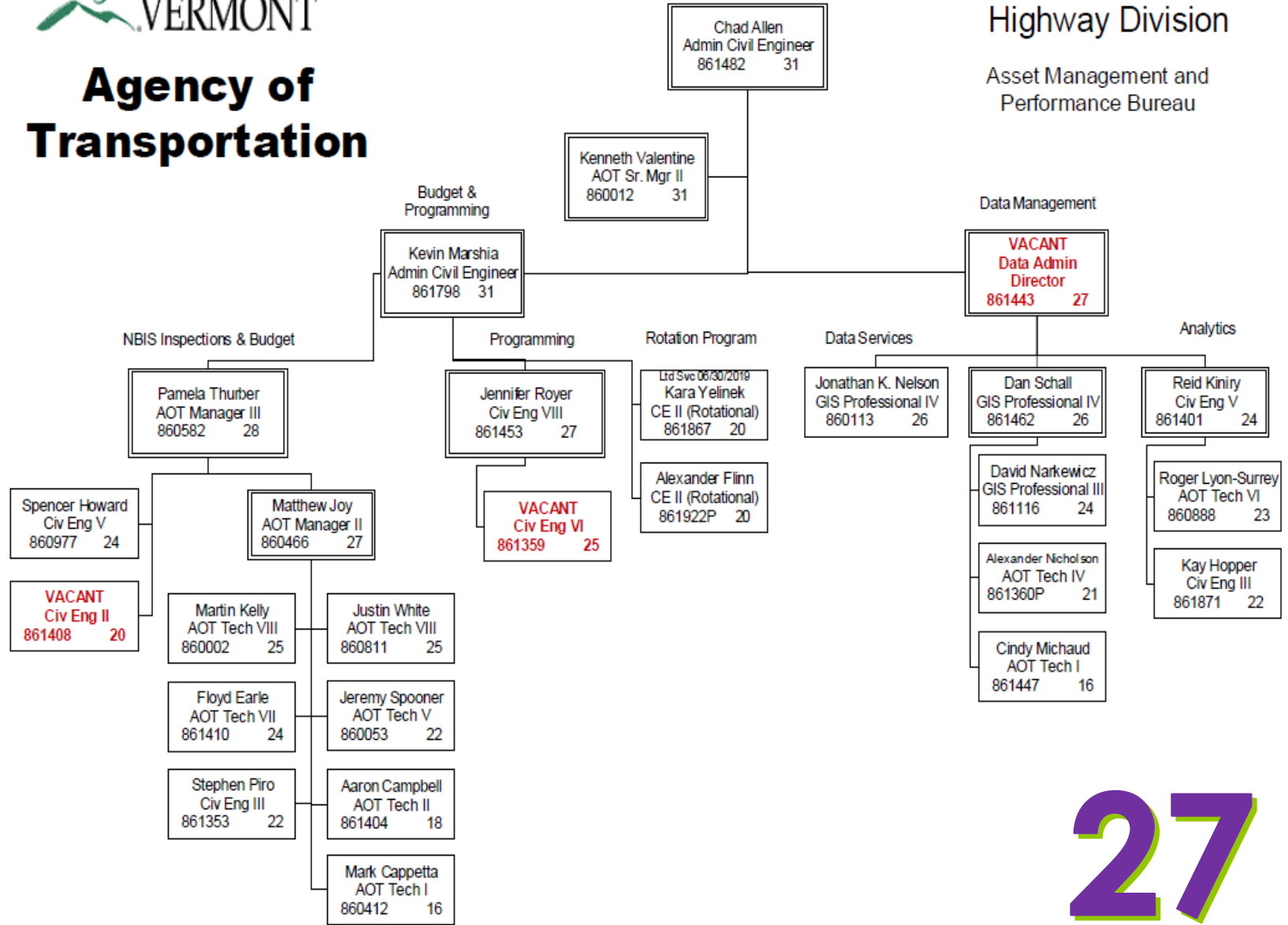

27

Functional Roles & Responsibilities

- Budget Development, Monitoring & Tracking
- Work Programming
 - Maintenance
 - Capital
- Asset Performance Tracking & Mgmt
- Asset Investment Planning
- Corridor Management
- Data Management
- Data Collection
 - Condition, Location
- Information Mgmt
- Asset Mgmt Systems
- DMV
 - Oversize/Overweight Vehicle Permit Support
- Bridge Load Ratings
- Bridge Inspections
- Technical Assistance
 - Asset Inspections
 - GIS

“That’s great but what is Asset Management?”



Planning & Programming

Design

Data Inventory

Data Quality

Data Reporting

AM Lifecycle

Data Efficiency

Data Systems

Maintenance

Construction

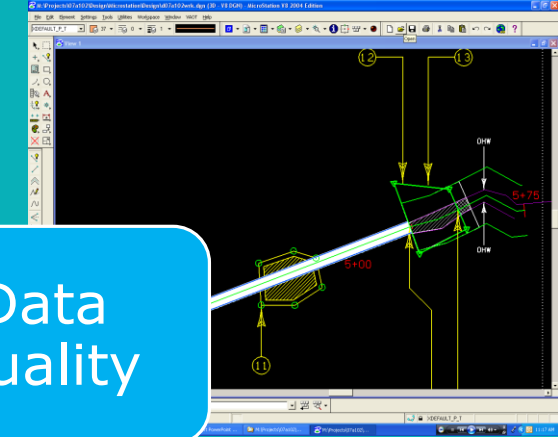
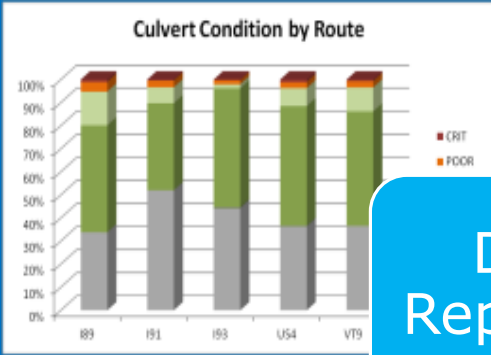

Pavement Condition

Unweighted Pavement Condition Distribution

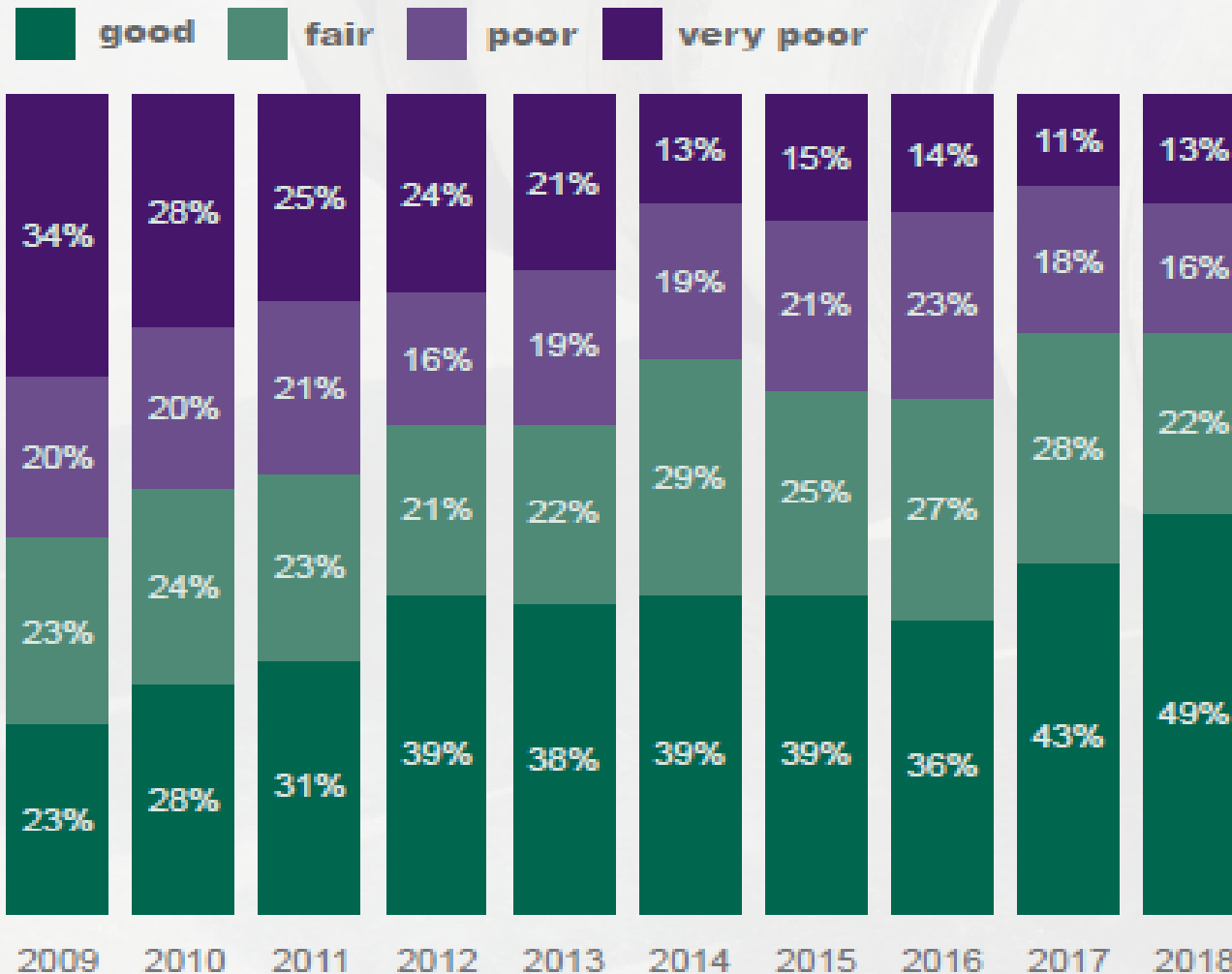

Bridge Condition

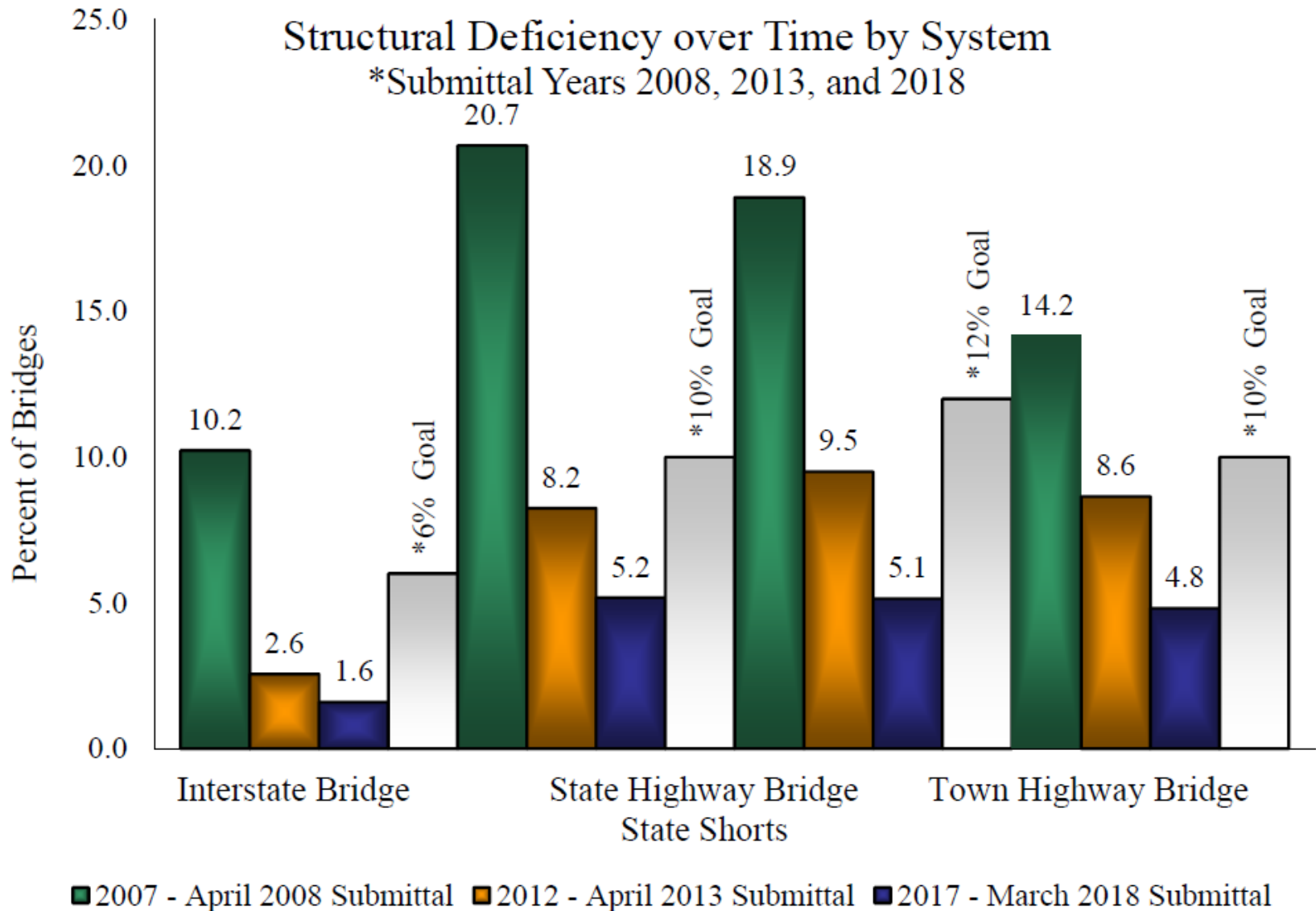

Where are we going?

- Increase Asset Sustainability Index, Initial ASI = 0.67
- Optimize Agency infrastructure budget based on ROI and develop 5 year credible programming schedule.
- Determine asset/corridor needs for a sustainable infrastructure, link to budget and funding sources and/or strategies.



AMP Vision - Where are we going?

- ◉ Develop AM plans for key assets
- ◉ Link plans to investment \$ and investment \$ to performance levels.
- ◉ Monitor Agency investment levels in each asset over time.



The Cost of "Timely" Maintenance

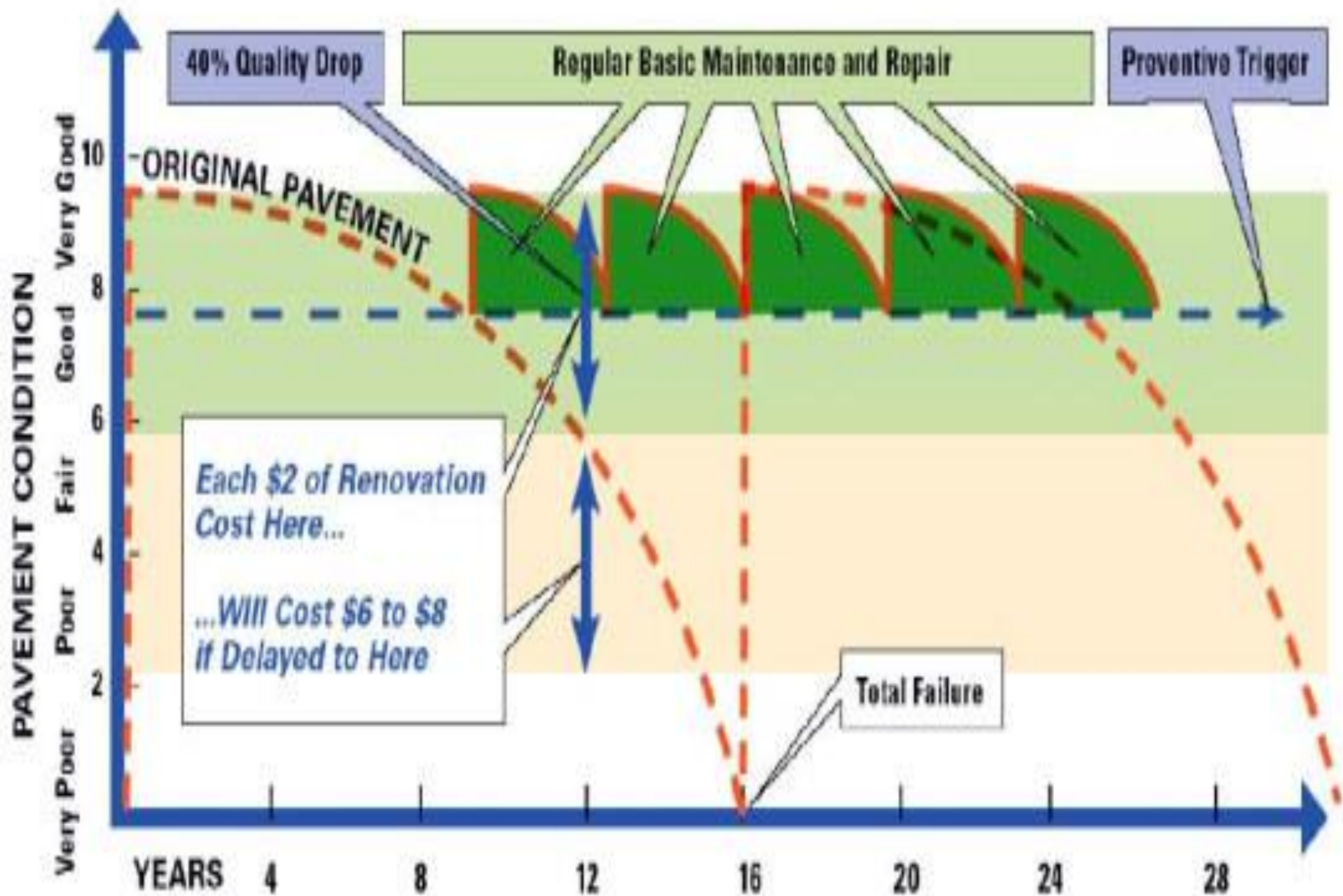

Pavements Bridges

Decisions, Decisions, Decisions...

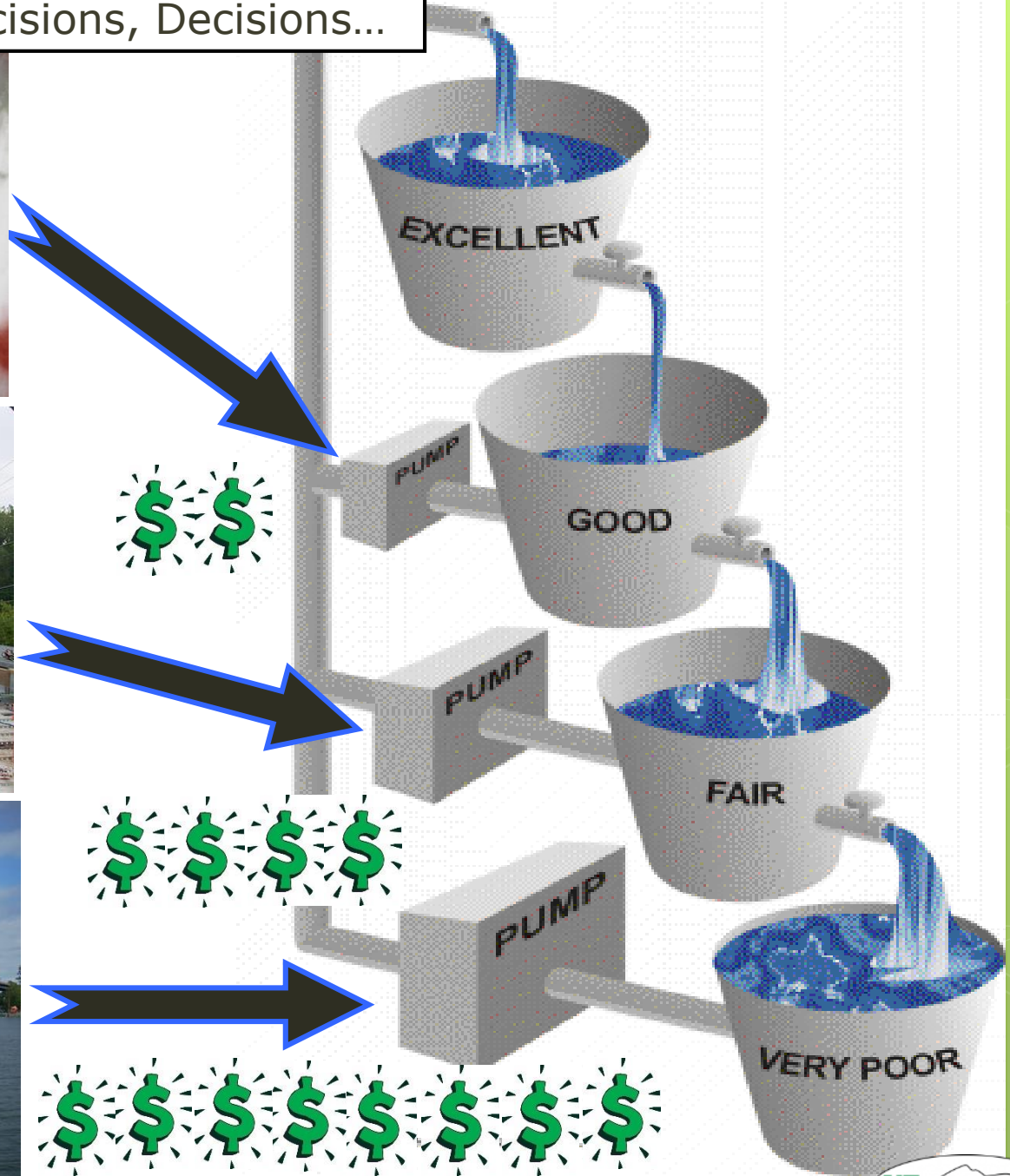
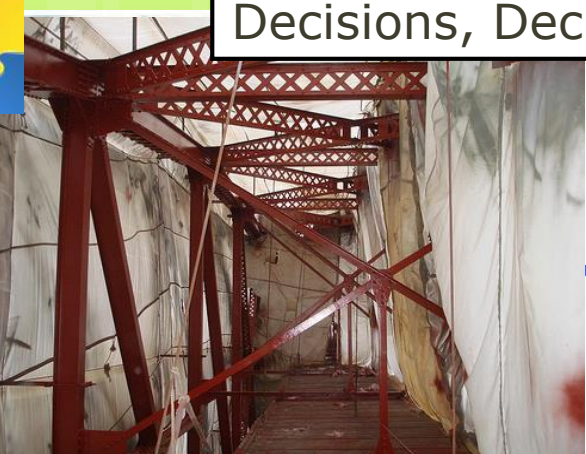

AM Timeline

1995

Initial Pavement Management System

2002

Initial AM Vision & Work Plan

2006

Road to Affordability

2007

ARRA Projects

2011

TS Irene

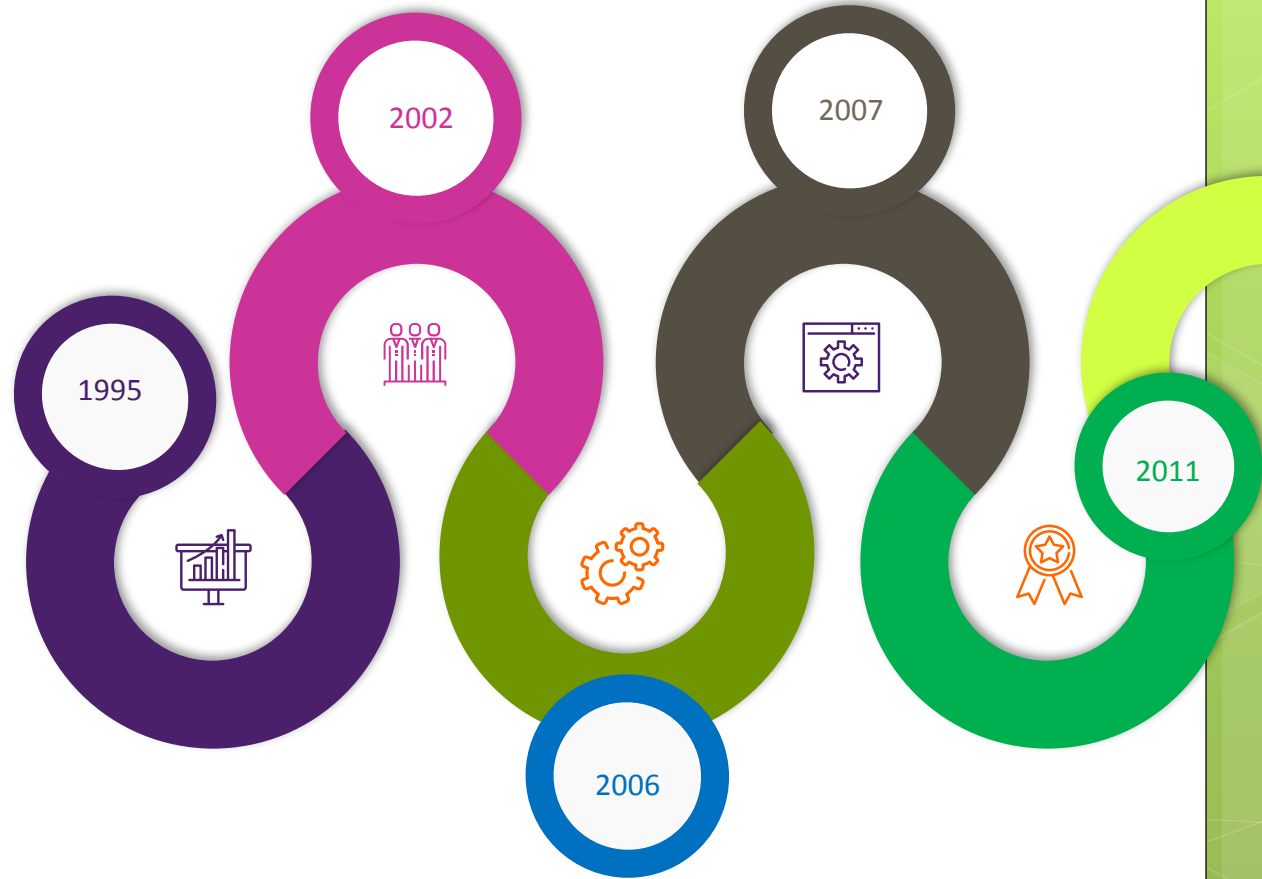

AM Timeline

2014

Inception of
the AM Bureau

2015

VTransparency

2019

TAMP

2019

VPSP2

2020

VAMIS
...end of the
beginning

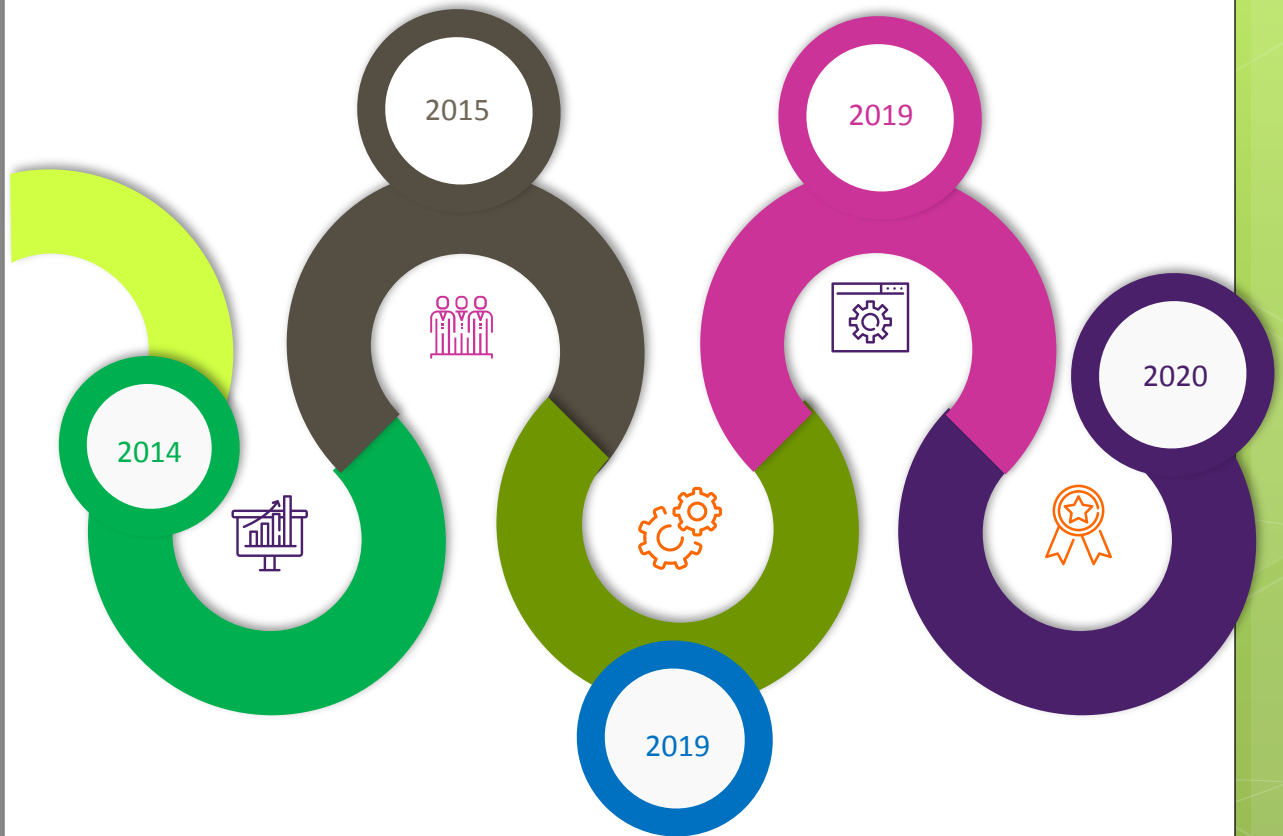

*Today's Decisions
Impact Tomorrow's
Performance*



Chad A. Allen, P.E. | Asset Management Bureau
chad.allen@vermont.gov | (802) 522-6948