

Elio Motors P4



P4 with wrap



P4 Interior





Mule 2: Perspective

Porsche 911



Honda Accord



BMW 330



Mustang GT





“Musts” of Elio Motors Project



Ultra-Low Sticker Price

- Current Status: \$6800.00; A/C . PW . PL . Radio. Standard
- On target to goal with 85% of the product cost supported by suppliers quotes

Ultra-High Mileage

- New design predicts 83.8 Hwy; 48.7 City

Safety Benefits = 5-Star Rating

- Each Elio comes equipped with a Safety Management System that includes three airbags-a reinforced roll-cage frame, Anti-Lock Braking System, and 50% larger crush zones than similar vehicles. Preliminary safety tests on computer models anticipate a 5-Star Safety Rating

Low Risk = Existing Technology

- The vehicle has been designed using existing systems from the incumbent supply base



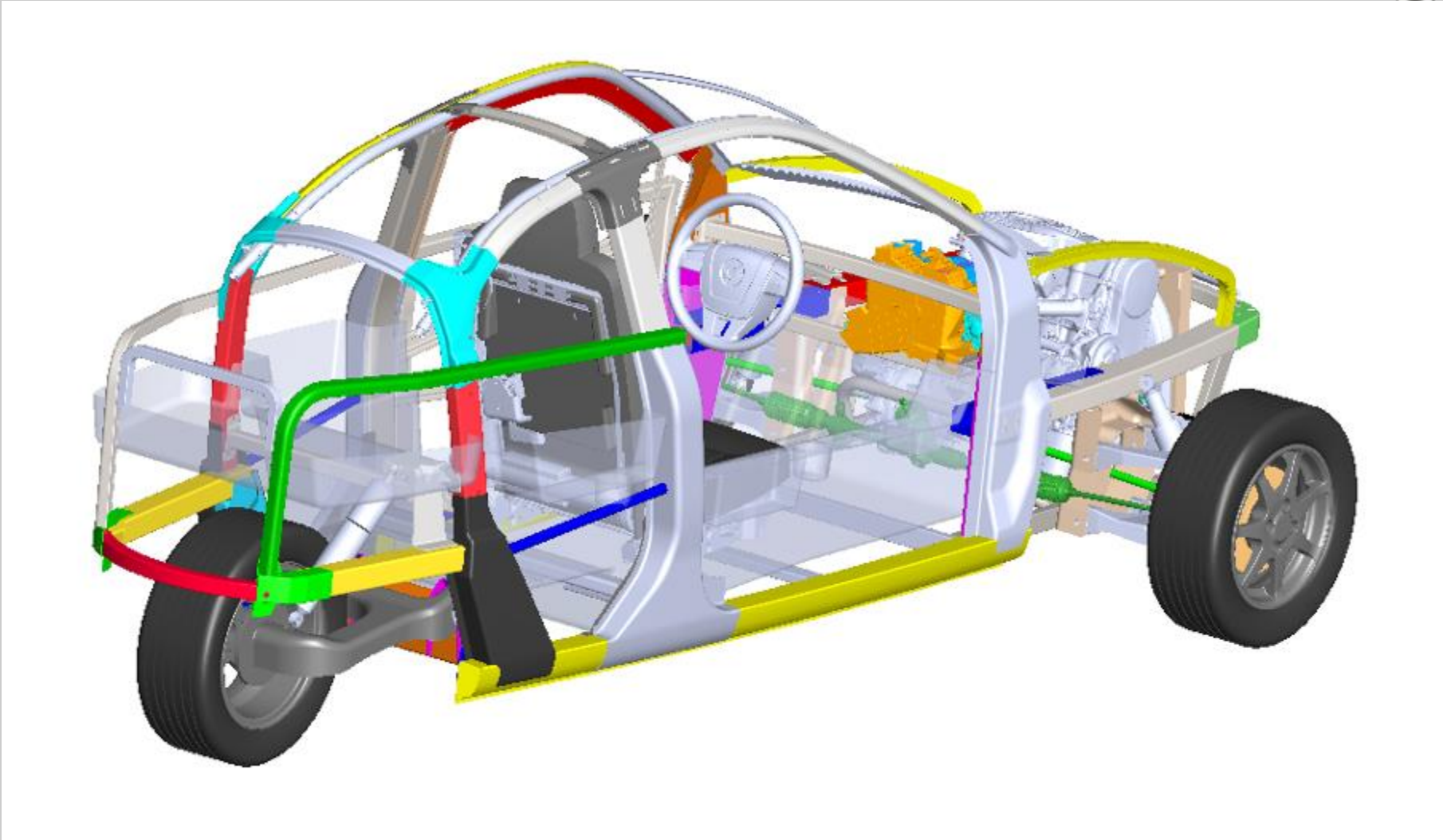

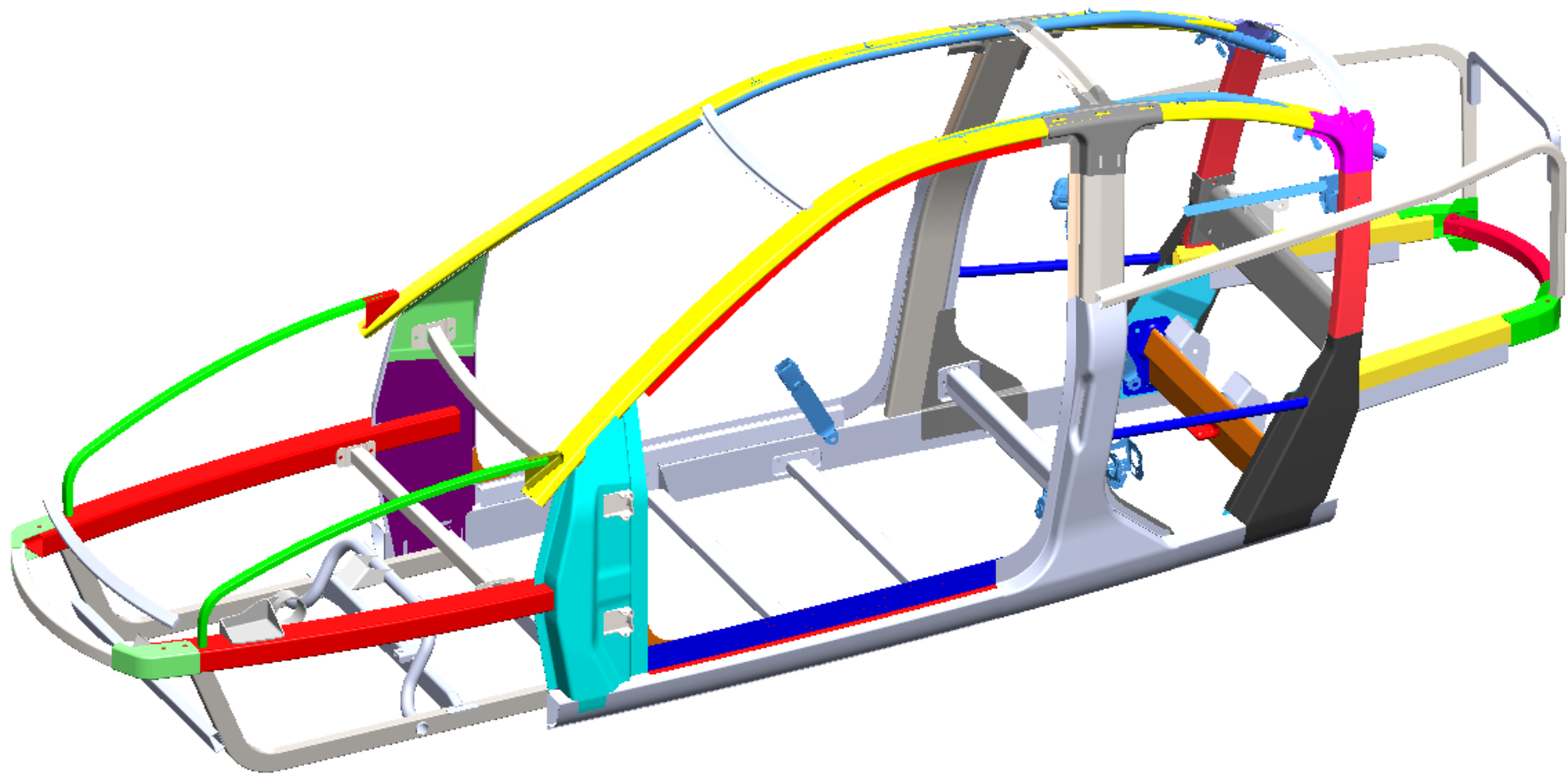

ISSUE IN VT



NHTSA will only certify the Elio as a motorcycle since it has “3 wheels in contact with the ground.” Our Certificate of Manufacturer’s Origin will indicate “motorcycle”

VT statute currently classifies the Elio as an automobile (the only state to do so). In order to register in VT, the Elio would have to carry an automobile certification from NHTSA or it could not be registered.

NHTSA will not certify the Elio as an automobile since it meets the definition of “motorcycle”

H 565 offered by Representative Brennan corrects this conflict and is consistent with NHTSA and AAMVA’s recommendations.